

Supporting Interactions Between Organizations with Language-Action Models

Peter Rittgen, University College of Borås, 501 90 Borås, Sweden, P: +46-33-435-5930, F: +46-33-435-4007, peter.rittgen@hb.se

ABSTRACT

A trading partner agreement can be used to regulate the cooperation of organizations. It is typically written in natural language which gives rise to misunderstandings when partners interpret it differently. In addition it is often compiled in an unsystematic way so that we might easily overlook a situation the contract should have covered. It is therefore desirable to have a method that can support the design of such an agreement in a controlled and structured fashion. We suggest an approach to this problem that is based on the Language-Action Perspective on organizations.

INTRODUCTION

The increasing complexity of products and services forces an increasing number of companies to cooperate more closely. This means that there is also an increasing need for the integration of business processes. Through a detailed analysis of the interactions between the organizations we can determine the design of a suitable agreement between the parties that can provide support for interorganizational workflows. The next section motivates the use of a particular perspective, the language-action perspective, for modeling interactions between (and within) organizations. For this purpose we select an appropriate language, DEMO, and motivate this choice.

One of the DEMO models, the Interaction Model, describes how organizations or organizational units interact with each other. This is the basis for more detailed models of collaboration which can also support the design of a contract regulating the cooperation. The design process is structured and systematic which makes it less error-prone. As the contract (also called trading partner agreement, TPA) is in part formulated in a rigorous language, the enforcement of the agreement is also facilitated. This implies a cost reduction for writing and enforcing contracts and hence lower transaction costs.

The remaining sections of the paper are structured as follows. First we give an overview of the Language-Action Perspective on Organizations. We proceed by giving an outline of the structure of trading-partner

Figure 1. The design of a trading partner agreement based on an interaction model

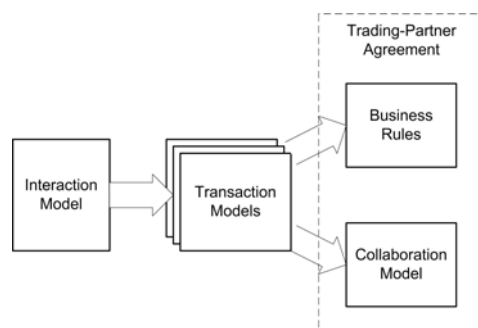

agreements. We take a closer look at two of their components, Business Rules and Collaboration Model, and show how they can be derived from the detailed description of the interorganizational interaction that is contained in the Transaction Models. Fig. 1 depicts the overall process.

All examples and figures used in this paper are excerpts from the real models we designed in the course of a consulting project where we tested the feasibility of our approach. The section “A Case Study” gives further details on this project. Last but not least we conclude this paper by summarizing the main arguments and specifying directions for further work.

A LANGUAGE-ACTION PERSPECTIVE ON ORGANIZATIONS

At the core of the Language-Action Perspective is the Speech-Act Theory by Austin and Searle (Austin, 1962; Searle, 1969). The central premise of this theory claims that language is a means of action. Habermas (1984) embedded this theory of speech acts into a social context whereby language action becomes social action. In an organizational setting communication is often aimed at the performance of a specific action (“getting a job done”) to achieve some objective. Templates for such goal-driven conversations are the Conversation-for-Action schema (Winograd and Flores, 1986) and the Action-Workflow Loop (Medina-Mora et al., 1992; Denning and Medina-Mora, 1995). They provide a stable framework for the analysis of organizations in general and business processes in particular. More sophisticated examples of such frameworks are: Dynamic Essential Modelling of Organizations (DEMO; Dietz and Habing, 2004; Liu et al., 2003; Dietz, 1999), Action-Based Modeling (Lehtinen and Lyytinen, 1986), Business Action Theory and SIMM (Goldkuhl and Lind, 2004; Goldkuhl and Röstlinger, 1993; Goldkuhl, 1996).

The research addressed in the preceding paragraph shows that organizational behavior is deeply rooted in language action. All coordination is essentially communicative. With the help of language we build and maintain organizations. It is used to delegate, report, inform, negotiate, sanction, hire, show the ropes, and so on. The importance of communication is even more obvious in an interorganizational context where we cannot rely on a common structure when coordinating activities that cross the boundaries between organizations. This raises a demand for additional communication, particularly in two areas. Firstly a contract has to be negotiated that regulates the relation between the cooperating parties, and secondly there is also an increased need for communication between members of different organizations in the daily routine work.

DEMO

The Language-Action Perspective offers many approaches some of which we have already mentioned. We have chosen DEMO because it offers transactional patterns not only in the metalanguage but also as concepts in the modeling language itself. This allows us to distinguish between transactions (as complex communicative actions) and speech-

acts (as elementary actions) which is essential for our approach (see section “Transaction Models”).

In DEMO, all acts that serve the same purpose are collected in a *transaction* in which two roles are engaged: the *initiator* and the *executor*. A transaction is assumed to follow a certain pattern which is divided into 3 sequential phases: *order* (O), *execute* (E) and *result* (R). In the order phase the contract is negotiated. This involves typically a *request* being made by the initiator and a *promise* by the executor to carry out the request. In the next phase the contract is executed which involves factual changes in the object world (as opposed to the intersubject world of communication). Finally, in the result phase the executor *states* that the agreed result has been achieved and the initiator *accepts* this *fact*. If anything goes wrong on the success layer, the participants can decide to move to the discussion or discourse layer. For details on the layers see (Reijswoud, 1996).

DEMO’s Interaction Model

The Interaction Model shows actors and transactions. The actors are roles that are enacted by a person, an organizational unit or a whole organization. Fig. 2 shows the Interaction Model of our case. The main actors are the Logistics Provider, the Headquarters of the retailer and the Shop. The latter two maintain a very close, franchise-like relationship but are nevertheless organizations in their own right.

Fig. 2 describes the process of capacity reservation and order handling among these organizations. It starts when Headquarters reserve capacity for handling a certain amount of ordered items 6 months, 2 months and 2 weeks in advance of the actual order (T4). These reservations represent forecasts with increasing accuracy the closer they are to the date of delivery. The Logistics Provider (LogPro) allocates staff and space so that the reserved capacity can be provided at the time the respective order arrives. Orders for products can be initiated either by Headquarters or by the Shop. The former happens when the Shop is running low on certain products. Headquarters will in such a case suggest to the Shop to place a refill order (T2). For this purpose they send an order proposal containing the products in question which, after possible changes and/or additions is returned. If customers ask for specific products, the Shop can also place a so-called customer order (T1). Headquarters will forward both types of orders to LogPro (T5). The delivery to the Shop will then be performed by LogPro which includes picking items, packing them and handing them over to the carrier. This activity is largely non-communicative and material and it is therefore not explicit in the Interaction Model. We only represent the coordinative part of it, namely the Shop receiving the delivery (T3). This consists of the arrival of the goods and a confirmation. The arrival is a material action which also has a communicative function: Through it LogPro states that they have performed the delivery and thereby fulfilled their obligation. The confirmation can be accompanied by a complaint if items are missing or wrong ones have been sent.

Periodically Headquarters will also ask for an update of the stock (T6). This is necessary because they run their own “virtual” warehouse

Figure 2. Interaction model

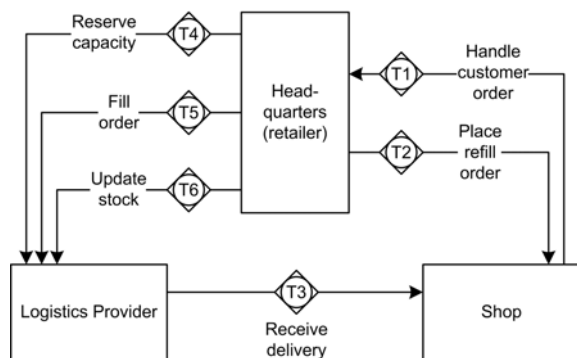

management system which is not integrated with the “physical” warehouse management system of LogPro.

Transaction Models

Much of the detailed behavior that constitutes a business process is hidden inside each transaction. For the specification of the TPA this has to be brought to light. A transaction in DEMO is made up of a number of speech acts and an objective action.

The actagenic conversation (O phase) has at least two elements: a *request* and a *promise* (see fig. 3). If an agreement was reached in the order phase, the objective action (E phase) is executed and the factagenic conversation (R phase) is entered. As a minimum this can consist of the speech acts *state* and *accept*. Fig. 3 summarizes these steps which are performed in the order that is indicated by the leading numbers. A model that contains only actors, speech acts and objective actions is called a Speech-Act Model. A Speech-Act Model that contains only actions and actors belonging to one transaction is called a Transaction Model.

Fig. 4 shows the complete, minimum Speech-Act Model of the Interaction Model in fig. 2. As Speech-Act Models can be very complex for realistic cases we will usually refer to a set of Transaction Models instead.

TRADING PARTNER AGREEMENTS

A Trading Partner Agreement is a formal, contractual representation of the cooperation between a number of organizations. It consists of a static and a dynamic part. In the static part we can find product or service specifications, prices and general conditions. The dynamic part defines the roles that each party to the contract plays and the activities they perform in the context of the cooperation. It is this dynamic part that we focus on. In principle we could claim that the Speech-Act Model already contains most of the information necessary for this part but this approach is not sufficient for at least two reasons. Firstly this model is typically very complex for realistic cases as the example of fig. 4 indicates. It is therefore unsuitable for communicating knowledge about the obligations to the respective parties. But one of the most important requirements of a good contract is that the parties signing it should be fully aware of their obligations.

Secondly the Speech-Act Model is hard to implement. It does not give us any directions as to which of its activities are supported by information systems integration and which not. Both issues can be addressed by dividing the behavioral model into two components: *Business Rules* and *Collaboration Model*. The latter is a detailed, workflow-like model of the cooperation. It is structurally very similar to the Speech-Act Model but it contains only a fraction of the actions. It shows only standard, routine behavior that can be performed or largely supported by information systems integration. This facilitates the enforcement of the contract.

The Business Rules then cover exceptional or non-routine behaviour. This kind of behavior does not occur often enough to economically justify an integration of the involved information systems. Such behaviour would also crowd the Collaboration Model. It can be better represented in form of a table. The next section describes the development and the use of the Collaboration Model and the Business Rules in detail.

Figure 3. Speech-act model of a transaction (transaction model of T1)

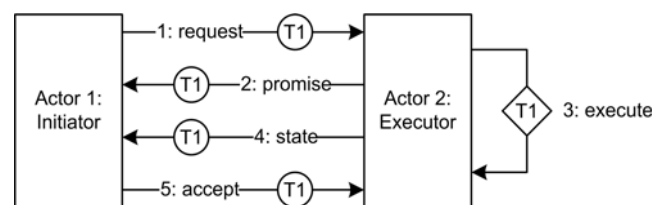
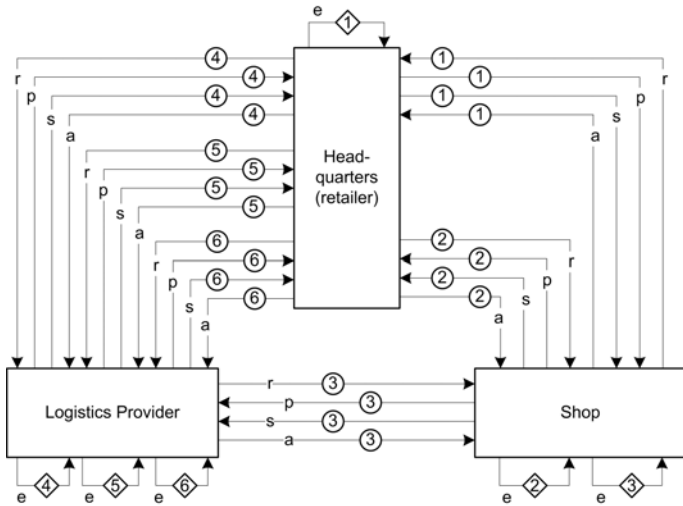

Figure 4. Complete speech-act model of the interactions



Collaboration Model and Business Rules

When developing the Trading Partner Agreement we look at each transaction in turn. We first create a Speech-Act Model of the respective. The result is a very detailed model with all the steps that have to be performed in the course of the transaction. Fig. 5 shows as an example the Speech-Act Model that corresponds to transaction T5.

The aim of that transaction is to fill the order, i.e. to deliver the items contained in the order. It starts when Headquarters send a so-called pick list to LogPro. This list names the products to be picked (and delivered) and their quantities. The associated activity is a routine activity and the information is important for controlling the process of filling the order. It will therefore be entered into the Collaboration Model (see fig. 6). The information systems of Headquarters and LogPro are integrated in such a way that the list is sent electronically as a “pick file”.

The next step in transaction T5 is that LogPro confirms the receipt of the pick list. As the warehouse management system of Headquarters mirrors that of LogPro an out-of-stock situation occurs rarely. LogPro only has to confirm that enough resources are available (staff, shelf space) to handle the order. As the reserved capacity (T4) is usually sufficient an explicit confirmation is not required but is per default assumed. The respective speech act does not appear in the Collaboration Model. Instead we create a Business Rule for the exception, i.e. if the required capacity does exceed the reserved one by more than the specified percentage value (see table 1, T5, promise). As a special arrangement has to be made for solving this problem in each specific case this activity cannot be supported by information systems integration. The logistics managers at both companies have to negotiate a solution.

The objective action “Fill order” is not considered in the TPA because it concerns only internal behavior of LogPro. The next step in transaction T5 is that LogPro reports the delivery. This is a routine activity and Headquarters needs this information for billing purposes. It is therefore a part of the Collaboration Model. The final step, confirm

Figure 5. Speech-act model of transaction T5

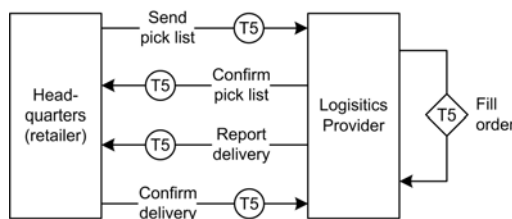

Figure 6. Collaboration model

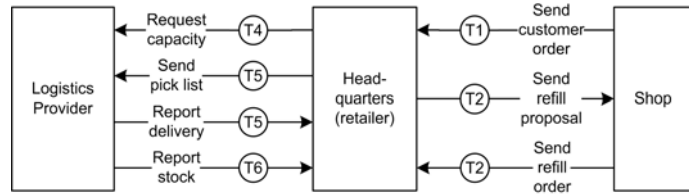

Table 1. Business rules

Transaction	Phase	Business Rule
T1	promise	A request to deliver items is per default granted and hence not confirmed. In case of out-of-stock a respective notification is sent.
	state, accept	covered by transition T3
T2	state, accept	covered by transition T3
	request, promise	covered by transition T1 or T2
T3	accept	If ‘confirm receipt’ was O.K. no further message is sent. Otherwise the claim is processed (return/resend).
	request, promise	A request for a capacity (forecast of required capacity) is always accepted and hence not confirmed.
T4	state, accept	The provision of the requested capacity is guaranteed. Hence no confirmation is required.
	promise	The pick list is accepted per default, no confirmation is sent. If the amount of items to be picked exceeds the limit specified in the general terms and conditions of this agreement (in relation to the reserved capacity), a special arrangement is made (rescheduling of warehouse staff / higher unit price).
T5	accept	This is implied by the receipt of the delivery. If items are missing or wrong ones have been sent a respective complaint is sent to LogPro and wrong items are returned to LogPro.
	request, promise	The updating of the retailer’s warehouse system is done via an automatic, daily file transmission containing a stock report. Request and promise are therefore obsolete.
T6	accept	The receipt of the stock report is assumed. If transmission fails, manual troubleshooting will be invoked.

delivery, is implied by the receipt of the delivery (T3). The exceptional case of a wrong delivery is handled by Business Rule T5, accept (see table1).

The same is done for the remaining transactions T1 – T4 and T6. This leads to the complete Collaboration model in fig. 6 and the complete list of Business Rules in table 1.

A CASE STUDY

The approach we have described so far was tested in a project that we carried out with representatives from both the Logistics Provider and their customer, a retail chain. One of the aims of that project was to improve the existing Trading Partner Agreement. Our approach helped us to develop a proposal for a new contract based on a thorough analysis of the interorganizational business process. The old contract was vague which led to a series of problems:

1. Indistinct communication structures: It was often unclear who communicates with whom regarding which issue.
2. Lack of trust: Different interpretations of the contract by the parties led to expectations that were not fulfilled.
3. Lack of information: LogPro was not provided with the information they need for a reliable capacity planning. This had not been specified clearly in the old TPA.
4. Excessive communication: A considerable amount of personal interorganizational communication was spent on handling everyday work. This was only necessary because of insufficient specification of routine procedures in the TPA.

5. High transaction costs: Ad-hoc solutions to exceptional problems increased transaction costs.

Using the approach introduced in the previous sections we developed a proposal for a new TPA that addressed the issues 1, 2, 4 and 5. The new contract specified more precisely the obligations of each party concerning the behavior at the interface between the organizations. This reduces the room for interpretation of the TPA which leads to more realistic expectations and ultimately to increased trust (issue 2). The Collaboration Model clearly states who interacts with whom regarding which issue. This clarifies the communication structures (issue 1) and reduces the amount of “unnecessary” communication (issue 4). Business Rules specify the behavior in exceptional situations eliminating the need for developing ad-hoc solutions. This reduces transaction costs (issue 5).

Conclusions

A language-action model of the interactions between organizations can contribute towards the design of Trading Partner Agreements. In particular the Interaction Model of DEMO allows us to develop first the Transaction Models, detailed Speech-Act Models of each transaction, and ultimately the dynamic constituents of the contract: Collaboration Model and Business Rules. The former represents routine behavior that is typically supported or performed by an integration of the respective information systems and it is formally a reduced version of the complete Speech-Act Model that provides the same level of precision. The latter complements the former and describes the exceptional and/or situational behavior in a less formal, textual manner in form of a table.

A TPA that is developed in this way is less ambiguous which facilitates the implementation of the procedures and the enforcement of the rules and conditions. This can reduce transaction costs, the need for extraneous communication and the reliability of commitments. Ultimately this leads to an increased level of service quality and improves the mutual trust among the participants in the cooperation.

REFERENCES

- Austin, J.L. (1962). *How to Do Things with Words*. Oxford University Press, Oxford, UK.
- Denning, P.J. and Medina-Mora, R. (1995). Completing the Loops. *Interfaces* 25 (3), pp. 42-57.
- Dietz, J.L.G. (1999). Understanding and modeling business processes with DEMO. In *Proceedings of the 18th International Conference on Conceptual Modeling ER '99* (Akoka, J.; Bouzeghoub, M.; Comyn-Wattiau, I. and Métais, E.; Eds.), pp. 188-202, Springer, Berlin, Germany.
- Dietz, J.L.G. and Habing, N. (2004). The Notion of Business Process Revisited. In *Proceedings of the OTM Confederated International Conferences, CoopIS, DOA, and ODBASE* (Meersman, R. and Tari, Z.; Eds.), pp. 85-100, Springer, Berlin, Germany.
- Goldkuhl, G. (1996). Generic business frameworks and action modelling. In *Proceedings of the First International Workshop on Communication Modeling* (Dignum, F.; Dietz, J.; Verharen, E. and Weigand, H.; Eds.), Electronic Workshops in Computing, Springer, Berlin, Germany.
- Goldkuhl, G. and Lind, M. (2004). The generics of business interaction - emphasizing dynamic features through the BAT model. In *Proceedings of the 9th International Working Conference on the Language-Action Perspective on Communication Modelling LAP 2004* (Aakhus, M. and Lind, M.; Eds.), pp. 1-26, Rutgers University, New Brunswick, NJ, USA.
- Goldkuhl, G. and Röstlinger, A. (1993). Joint elicitation of problems: An important aspect of change analysis. In *Human, Organizational, and Social Dimensions of Information Systems Development* (Avison, D.; Kendall, J. and Degross, J.; Eds.), North-Holland, Amsterdam, The Netherlands.
- Habermas J. (1984). *The Theory of Communicative Action I, Reason and the Rationalization of Society*. Beacon Press, Boston, MA, USA.
- Holland, C.P. and Lockett, A.G. (1997). Mixed Mode Network Structures: The Strategic Use of Electronic Communication by Organizations. *Organization Science* 8(5), pp. 475-488.
- Lehtinen, E. and Lyytinen, K. (1986). An Action Based Model of Information Systems. *Information Systems* 11(4), pp. 299-317.
- Liu, K.; Sun, L.; Barjis, J. and Dietz, J.L.G. (2003). Modelling dynamic behaviour of business organisations - extension of DEMO from a semiotic perspective. *Knowledge-Based Systems* 16(2), pp. 101-111.
- Medina-Mora, R.; Winograd, T.; Flores, R. and Flores, F. (1992). The Action Workflow Approach to Workflow Management Technology. In *Proceedings of the Conference on Computer-Supported Cooperative Work CSCW'92* (Turner, J. and Kraut, R.; Eds.), pp. 281-288, ACM, New York, NY, USA.
- Reijswoud V.E. van (1996). *The Structure of Business Communication: Theory, Model and Application*. PhD Thesis, TU Delft, The Netherlands.
- Searle, J.R. (1969). *Speech Acts, An Essay in the Philosophy of Language*. Cambridge University Press, London, UK.
- Winograd T. and Flores, F. (1986). *Understanding Computers and Cognition: A New Foundation for Design*. Ablex, Norwood, NJ, USA.